

EMC Test Report
For
Shandong Xiaoya Group Household Appliances Co., Ltd.
Ozone Air Sterillizer
Model: XY-850S,XY-835S

Prepared For : **Shandong Xiaoya Group Household Appliances Co., Ltd.**
No.44 Gongye bei Road,Licheng District,Jinan City, China

Prepared By : **Beide (Shenzhen) Product Service Limited**
China: 6F, Bldg E, Hourui 3rd Ind Zone, Xixiang, Bao'an Dist,
Shenzhen, China

Report Number: B-E200327993
Date of Test: Mar.04-09,2020
Date of Report: Mar.10,2020

TABLE OF CONTENT

Description	Page
Test Report Declaration	
1. TEST RESULTS SUMMARY	5
2. GENERAL INFORMATION	6
2.1. Report Information	6
2.2. Description of Device (EUT).....	6
2.3. Test Facility	6
2.4. Test Uncertainty	6
2.5. Test Condition	7
2.6. Test Conditions.....	7
2.7. Performance Criterion	7
3. TEST INSTRUMENT USED	8
3.1. For Conducted Emission Test.....	8
3.2. For Radiation Emission Test	8
3.3. For Harmonic / Flicker Test	8
3.4. For Electrostatic Discharge Immunity Test	8
3.5. For Radio Frequency Electromagnetic Field	9
3.6. For Electrical Fast Transient/Burst Test	9
3.7. For Surge Test	9
3.8. For Injected Currents Susceptibility Test	9
3.9. For Voltage Dips and Interruptions Test	9
4. POWER LINE CONDUCTED EMISSION TEST	10
4.1. Block Diagram of Test Setup	10
4.2. Test Standard	10
4.3. Power Line Conducted Emission Limit.....	10
4.4. EUT Configuration on Test	10
4.5. Operating Condition of EUT	11
4.6. Test Procedure	11
4.7. Power Line Conducted Emission Test Results	11
5. RADIATION EMISSION TEST	12
5.1. Block Diagram of Test Setup	12
5.2. Test Standard	12
5.3. Radiation Emission Limit	12
5.4. EUT Configuration on Test	12
5.5. Operating Condition of EUT	13
5.6. Test Procedure	13
5.7. Radiation Emission Test Results	13
6. HARMONIC CURRENT EMISSION TEST	14
6.1. Block Diagram of Test Setup	14
6.2. Test Standard	14
6.3. Operating Condition of EUT	14
6.4. Test Results.....	14
7. VOLTAGE FLUCTUATIONS & FLICKER TEST	15
7.1. Block Diagram of Test Setup	15
7.2. Test Standard	15
7.3. Operating Condition of EUT	15
7.4. Test Results.....	15
8. ELECTROSTATIC DISCHARGE TEST	16
8.1. Block Diagram of Test Setup	16
8.2. Test Standard	16
8.3. Severity level and Performance criterion.....	17
8.4. EUT Configuration on Test	17

8.5. Operating Condition of EUT	17
8.6. Test Procedure	17
8.7. Test Results.....	17
9. RF FIELD STRENGTH SUSCEPTIBILITY TEST	19
9.1. Block Diagram of Test Setup	19
9.2. Test Standard	19
9.3. Severity level and Performance criterion.....	19
9.4. EUT Configuration on Test	19
9.5. Operating Condition of EUT	19
9.6. Test Procedure	20
9.7. Test Results.....	20
10. ELECTRICAL FAST TRANSIENT/BURST TEST	22
10.1. Block Diagram of Test Setup	22
10.2. Test Standard	22
10.3. Severity level and Performance criterion.....	22
10.4. EUT Configuration on Test	22
10.5. Operating Condition of EUT	23
10.6. Test Procedure	23
10.7. Test Results.....	23
11. SURGE TEST.....	25
11.1. Block Diagram of Test Setup	25
11.2. Test Standard	25
11.3. Severity level and Performance criterion.....	25
11.4. EUT Configuration on Test	25
11.5. Operating Condition of EUT	25
11.6. Test Procedure	26
11.7. Test Results.....	26
12. INJECTED CURRENTS SUSCEPTIBILITY TEST.....	28
12.1. Block Diagram of Test Setup	28
12.2. Test Standard	28
12.3. Severity Levels and Performance Criterion.....	28
12.4. EUT Configuration on Test	28
12.5. Operating Condition of EUT	28
12.6. Test Procedure	29
12.7. Test Results.....	29
13. VOLTAGE DIPS AND INTERRUPTIONS TEST	31
13.1. Block Diagram of Test Setup	31
13.2. Test Standard	31
13.3. Severity level and Performance criterion.....	31
13.4. EUT Configuration	31
13.5. Operating Condition of EUT	32
13.6. Test Procedure	32
13.7. Test Results.....	32
APPENDIX I (TEST DATA)	(4 pages)
APPENDIX II (EUT PHOTOS)	(2 pages)

TEST REPORT DECLARATION

Applicant : Shandong Xiaoya Group Household Appliances Co., Ltd.
Address : No.44 Gongye bei Road,Licheng District,Jinan City, China
Client No. : 05319987
Manufacturer : Same As Holder
EUT Description : Ozone Air Sterillizer
Model No. : XY-850S,XY-835S
Remark : Use XY-850S do all the tests.
Technical Data : 220-240V~,50Hz,88W

Test Procedure Used:

EN 61000-6-3:2007+A1:2011; EN IEC 61000-6-1:2019;
EN IEC 61000-3-2:2019;
EN 61000-3-3:2013+A1:2019; (EN 61000-4-2:2009, EN 61000-4-3:2006+A2:2010,
EN 61000-4-4:2012, EN 61000-4-5:2014,
EN 61000-4-6:2014, EN 61000-4-11:2004)

The device described above is tested by Beide (Shenzhen) Product Service Limited to determine the maximum emission levels emanating from the device, the severe levels which the device can endure and EUT's performance criterion. The test results are contained in this test report. Beide (Shenzhen) Product Service Limited is assumed of full responsibility for the accuracy and completeness of these tests.

This report applies to above tested sample only and shall not be reproduced in part without written approval of Beide (Shenzhen) Product Service Limited.

Date of Test : Mar.04-09,2020

Prepared by : Shen Xiao
(Shen Xiao)

Checked by : Austin zhong
(Austin zhong)

Approved by : Martin wang
(Martin wang)



1. TEST RESULTS SUMMARY

Test Results Summary

Test Items	Test Results
1 Conducted Disturbance Test	PASS
2 Radiation Emission Test	PASS
3 Harmonic Current Emission Test	PASS
4 Voltage Fluctuations & Flicker Test	PASS
5 Electrostatic Discharge Test	PASS
6 Radio Frequency Electromagnetic Field	PASS
7 Electrical Fast Transient/Burst Test	PASS
8 Surge Test	PASS
9 Injected Currents Susceptibility Test	PASS
10 Voltage Dips And Interruptions Test	PASS

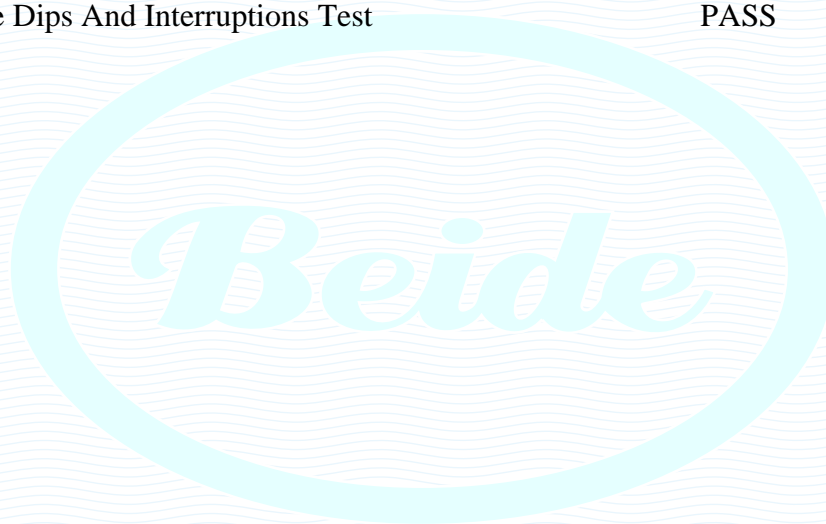

2.GENERAL INFORMATION

2.1.Report Information

2.1.1. This report is not a certificate of quality, it only applies to the sample of the specific product/equipment given at the time of its testing. The results are not used to indicate or imply that they are application to the similar items. In addition, such results must not be used to indicate or imply that BEIDE approves recommends or endorses the manufacture, supplier or use of such product/equipment, or that BEIDE in any way guarantees the later performance of the product/equipment.

2.1.2. The sample/s mentioned in this report is/are supplied by applicant, BEIDE therefore assumes no responsibility for the accuracy of information on the brand names, model number, origin of manufacture or any information supplied.

Additional copies of the report are available to the applicant at an additional fee. No third part can obtain a copy of this report through BEIDE, unless the applicant has authorized BEIDE in writing to do so.

2.2.Description of Device (EUT)

Description : Ozone Air Sterillizer
Number Model : XY-850S
Applicant : Shandong Xiaoya Group Household Appliances Co., Ltd.
No.44 Gongye bei Road,Licheng District,Jinan City, China
Manufacturer : Shandong Xiaoya Group Household Appliances Co., Ltd.
No.44 Gongye bei Road,Licheng District,Jinan City, China

2.3.Test Facility

Site Description
Tested by : Beide (Shenzhen) Product Service Limited
Site Location : China: 6F, Bldg E, Hourui 3rd Ind Zone, Xixiang, Bao'an Dist, Shenzhen, China

2.4.Test Uncertainty

Conducted Emission Uncertainty = $\pm 2.66\text{dB}$
Radiated Emission Uncertainty = $\pm 4.26\text{dB}$

2.5. Test Condition

Test Mode: ON

2.6. Test Conditions

Temperature: 22°C-28°C

Relative Humidity: 45%-68%

2.7. Performance Criterion

Performance criterion **A**:

The equipment shall continue to operate as intended during the test.

No change of actual operating state (for example change of channel) is allowed as a result of the application of the test.

Multifunction equipment shall for each function meet the relevant requirements.

Evaluation is carried out for audio and video functions.

Performance criterion **B**:

The equipment shall continue to operate as intended after the test. No loss of function is allowed after the test when the apparatus is used as intended. But failures which are recovered automatically but which cause temporary delay in processing, are permissible. No change of actual operating state for example change of channel or stored data and settings is allowed as a result of the application of the test. During the test, degradation of performance is allowed.

3. TEST INSTRUMENT USED

3.1. For Conducted Emission Test

Item	Equipment	Manufacturer	Model No.	Serial No.	Last Cal.	Cal. Interval
1.	Spectrum Analyzer	Agilent	E4402B-ESA	US1192821	2019.08.18	1 Year
2.	EMI Test Receiver	ROHDE&SCHWARZ	ESPI	101206	2019.08.18	1 Year
3.	L.I.S.N.	SCHWARZBECK	NSLK8126	8126-224	2019.08.18	1 Year
4.	L.I.S.N.	EMCO	3825/2	11977C	2019.08.18	1 Year

3.2. For Radiation Emission Test

Item	Equipment	Manufacturer	Model No.	Serial No.	Last Cal.	Cal. Interval
1.	Spectrum Analyzer	Rohde&schwarz	FSEA20	DE25181	2019.08.18	1 Year
2.	Positioning Controller	C&C	CC-C-1F	N/A	2019.08.18	1 Year
3.	Trilog Broadband Antenna	Schwarzbeck	VULB9163	9163-333	2019.08.18	1 Year
4.	Horn Antenna	Schwarzbeck	BBHX9120	9120-426	2019.08.18	1 Year
5.	RF Switch	EM	EMSW18	SW060023	2019.08.18	1 Year
6.	Amplifier	Agilent	8447F	3113A06717	2019.08.18	1 Year
7.	Coaxial Cable	Schwarzbeck	AK9513	9513-10	2019.08.18	1 Year
8.	EMI Test Receiver	Rohde&schwarz	ESPI	25498514	2019.08.18	1 Year

3.3. For Harmonic / Flicker Test

Item	Equipment	Manufacturer	Model No.	Serial No.	Last Cal.	Cal. Interval
1.	Signal Conditioning Unit	SCHAFFNER	CCN1000-1	23980/7	2019.08.18	1 Year
2.	Signal Phase Impedance Network	SCHAFFNER	INA2152	0929-2	2019.08.18	1 Year
3.	5KVA AC Power Source	SCHAFFNER	NSG1007	2983332	2019.08.18	1 Year

3.4. For Electrostatic Discharge Immunity Test

Item	Equipment	Manufacturer	Model No.	Serial No.	Last Cal.	Cal. Interval
1.	ESD Tester	Noiseken	ESS-200AX	0223	2019.08.18	1 Year

3.5. For Radio Frequency Electromagnetic Field

Item	Equipment	Manufacturer	Model No.	Serial No.	Last Cal.	Cal. Interval
1.	Signal Generator	IFR	2032	203002/100	2019.08.18	1 Year
2.	Amplifier	A&R	150W1000	301584	2019.08.18	1 Year
3.	Dual Directional Coupler	A&R	DC6080	301508	2019.08.18	1 Year
4.	Power Head	A&R	PH2000	301193	2019.08.18	1 Year
5.	Power Meter	A&R	PM2002	302799	2019.08.18	1 Year
6.	Field Monitor	A&R	FM5004	300329	2019.08.18	1 Year
7.	Field Probe	A&R	FP5000	300221	2019.08.18	1 Year

3.6. For Electrical Fast Transient/Burst Test

Item	Equipment	Manufacturer	Model No.	Serial No.	Last Cal.	Cal. Interval
1.	Ultra Compact Simulator	EM TEST	UCS500M6	0500-19	2019.08.18	1 Year

3.7. For Surge Test

Item	Equipment	Manufacturer	Model No.	Serial No.	Last Cal.	Cal. Interval
1.	Surge Tester	HAEFELY	PSURGE4.1	080107-04	2019.08.18	1 Year

3.8. For Injected Currents Susceptibility Test

Item	Equipment	Manufacturer	Model No.	Serial No.	Last Cal.	Cal. Interval
1.	Signal Generator	IFR	2032	203002/100	2019.08.18	1 Year
2.	Amplifier	A&R	150W1000	301584	2019.08.18	NCR

3.9. For Voltage Dips and Interruptions Test

Item	Equipment	Manufacturer	Model No.	Serial No.	Last Cal.	Cal. Interval
1.	Dips Tester	HEAFELY	PLINE 1610	083732-18	2019.08.18	1 Year

4. POWER LINE CONDUCTED EMISSION TEST

4.1. Block Diagram of Test Setup

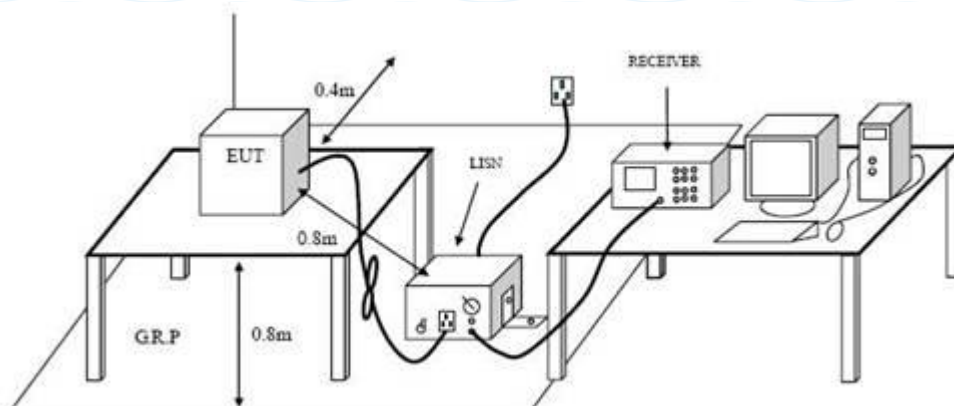

4.2. Test Standard

EN 61000-6-3:2007+A1:2011

4.3. Power Line Conducted Emission Limit

Frequency MHz	Limits dB(μ V)	
	Quasi-peak Level	Average Level
0.15 ~ 0.50	66 ~ 56*	56 ~ 46*
0.50 ~ 5.00	56	46
5.00 ~ 30.00	60	50

Notes: 1. *Decreasing linearly with logarithm of frequency.

2. The lower limit shall apply at the transition frequencies.

4.4. EUT Configuration on Test

The following equipments are installed on conducted emission test to meet the test requirement and operating in a manner, which tends to maximize its emission characteristics in a normal application.

4.4.1. Ozone Air Sterillizer

Model Number : XY-850S

Manufacturer : Shandong Xiaoya Group Household Appliances Co., Ltd.

4.5. Operating Condition of EUT

4.5.1. Setup the EUT and simulators as shown in Section 4.1.

4.5.2. Turn on the power of all equipments.

4.5.3. Let the EUT work in test mode (ON) and test it.

4.6. Test Procedure

The EUT is put on the ground and connected to the AC mains through an Artificial Mains Network (L.I.S.N.). This provided 50ohm-coupling impedance for the tested equipments. Both sides of AC line are checked to find out the maximum conducted emission levels according to the EN 61000-6-3 regulations during conducted emission test.

The bandwidth of the test receiver (R&S Test Receiver ESPI) is set at 10kHz.

The frequency range from 150 kHz to 30 MHz is investigated. The scanning waveform are attached within Appendix I.

4.7. Power Line Conducted Emission Test Results

PASS

5.RADIATION EMISSION TEST

5.1.Block Diagram of Test Setup

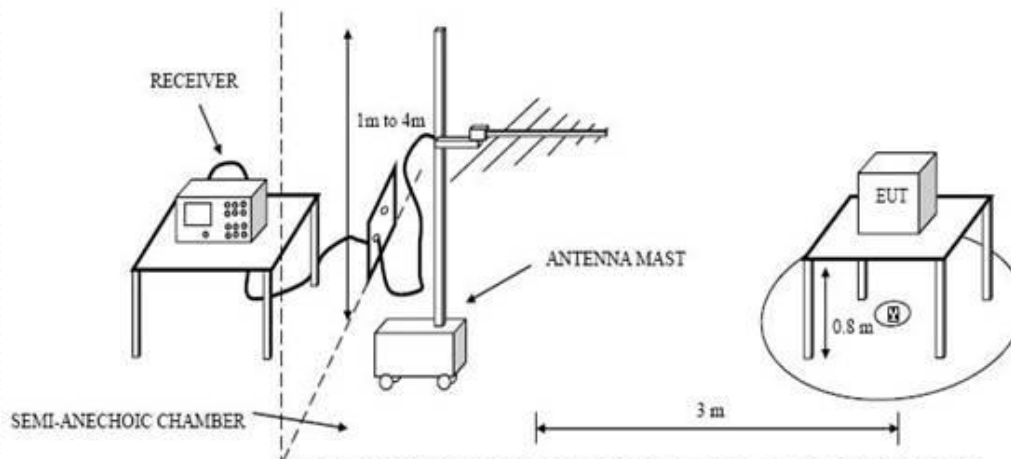

5.2.Test Standard

EN 61000-6-3:2007+A1:2011

5.3.Radiation Emission Limit

All emanations from a Class B computing devices or system, including any network of conductors and apparatus connected thereto, shall not exceed the level of field strengths specified below:

FREQUENCY (MHz)	DISTANCE (Meters)	FIELD STRENGTHS LIMITS (dB μ V/m)
30 ~ 230	3	40
230 ~ 1000	3	47

Notes: 1. The tighter limit shall apply at the edge between two frequency bands.
2. Distance refers to the distance in meters between the measuring instrument antenna and the closed point of any part of the EUT.

5.4.EUT Configuration on Test

The test Class B regulations test method must be used to find the maximum emission during radiated emission test.

The configuration of EUT is same as used in the test.

5.5.Operating Condition of EUT

- 5.5.1. Setup the EUT as shown on Section 5.1.
- 5.5.2. Turn on the power of all equipments.
- 5.5.3. Let the EUT work in test mode (ON) and measure it and test it.

5.6.Test Procedure

The EUT is placed on a turn table which is 0.8 meter above ground. The turn table can rotate 360 degrees to determine the position of the maximum emission level. The EUT is set 3 meters away from the receiving antenna which is mounted on a antenna tower. The antenna can move up and down between 1 to 4 meters to find out the maximum emission level. Broadband antenna(calibrated by dipole antenna) are used as a receiving antenna. Both horizontal and vertical polarization of the antenna is set on test.

The bandwidth setting on the test receiver(R&S TEST RECEIVER ESPI) is 120kHz. The EUT is tested in Anechoic Chamber.

5.7.Radiation Emission Test Results

PASS

6.HARMONIC CURRENT EMISSION TEST

6.1.Block Diagram of Test Setup

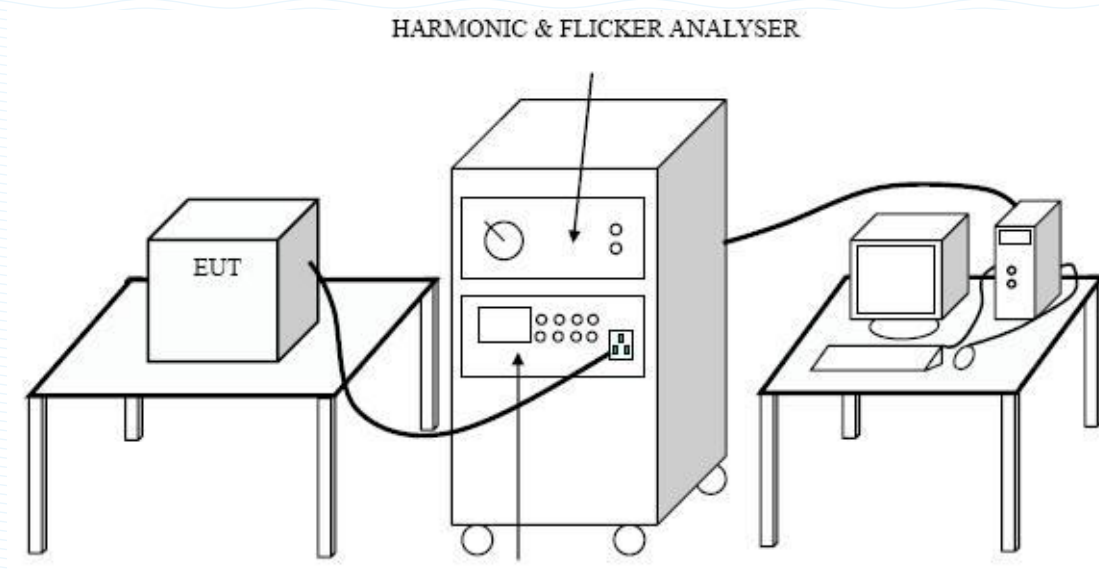

6.2.Test Standard

EN IEC 61000-3-2:2019, Class-A

6.3.Operating Condition of EUT

Same as Section 4.5 except the test set up replaced by Section 6.1.

6.4.Test Results

PASS

7.VOLTAGE FLUCTUATIONS & FLICKER TEST

7.1.Block Diagram of Test Setup

Same as Section 6.1.

7.2.Test Standard

EN 61000-3-3:2013+A1:2019

7.3.Operating Condition of EUT

Same as Section 4.5 except the test set up replaced by Section 7.1.

7.4.Test Results

PASS



8.ELECTROSTATIC DISCHARGE TEST

8.1.Block Diagram of Test Setup

8.1.1. Block Diagram of ESD Test Setup (Direct Discharge)

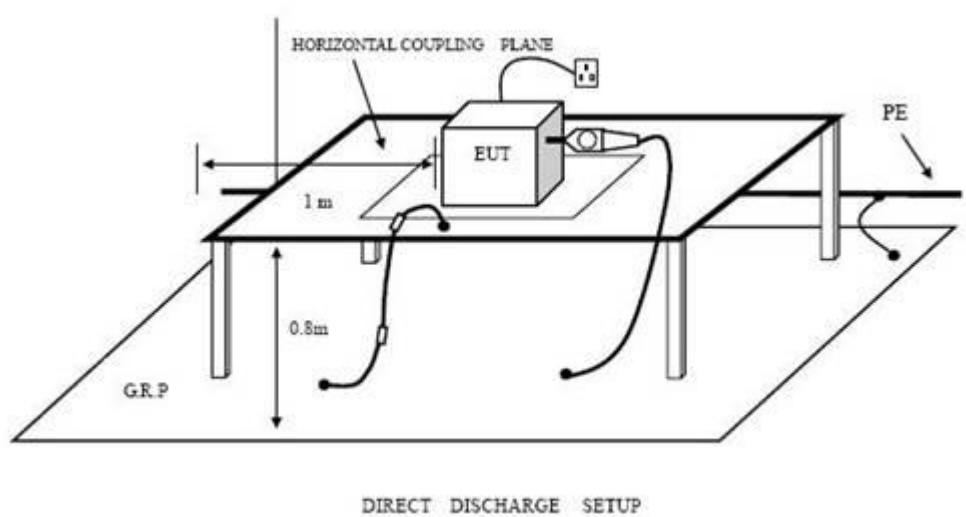

8.1.2. Block Diagram of ESD Test Setup (Indirect Discharge)

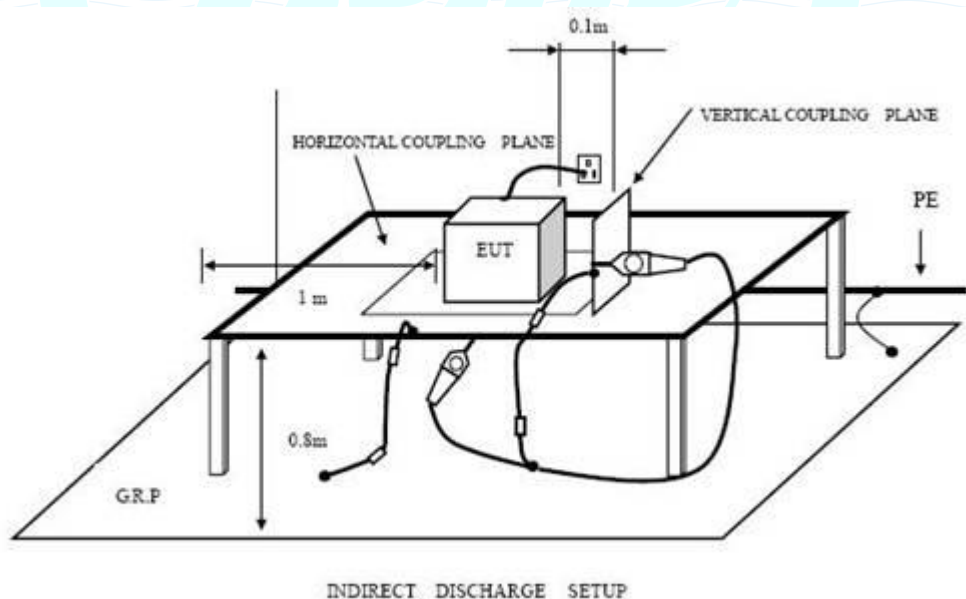

8.2.Test Standard

EN IEC 61000-6-1:2019 (EN 61000-4-2:2009)
Severity Level 3 for Air Discharge at 8kV
Severity Level 2 for Contact Discharge at 4kV

8.3. Severity level and Performance criterion

Severity level

Level	Test Voltage Contact Discharge (kV)	Test Voltage Air Discharge (kV)
1.	2	2
2.	4	4
3.	6	8
4.	8	15
X.	Special	Special

Performance criterion: **B**

8.4. EUT Configuration on Test

The configuration of EUT is listed in Section 4.4.

8.5. Operating Condition of EUT

8.5.1. Setup the EUT as shown in Section 4.5. except the test set up replaced by section 8.1.

8.6. Test Procedure

8.6.1. Air Discharge:

This test is done on non-conductive surfaces. The round discharge tip of the discharge electrode shall be approached as fast as possible to touch the EUT.

After each discharge, the discharge electrode shall be removed from the EUT.

The generator is then re-triggered for a new single discharge and repeated 10 times for each pre-selected test point. This procedure shall be repeated until all the air discharge completed.

8.6.2. Contact Discharge:

All the procedure shall be same as Section 8.6.1 except that the tip of the discharge electrode shall touch the EUT before the discharge switch is operated.

8.7. Test Results

PASS

Please refer to the following page.

Electrostatic Discharge Test Results

Beide (Shenzhen) Product Service Limited

Date: Mar.05, 2020

Applicant : Shandong Xiaoya Group	Test Date : Mar.05, 2020
Household Appliances Co., Ltd.	
EUT : Ozone Air Sterillizer	Temperature : 24°C
M/N : XY-850S	Humidity : 49%
Power Supply : AC 230V	Test Mode : ON
Test Engineer : Jack	

Air Discharge: ±8kV For each point positive 10 times and negative 10 times

Contact Discharge: ±4kV

Location		Kind		Result
		A-Air Discharge	C-Contact Discharge	
Slots	20 points	A		PASS
Surface	20 points	A		PASS
HCP	5 points	C		PASS
VCP	5 points	C		PASS

Discharge should be considered on Contact and Air and Horizontal Coupling Plane (HCP) and Vertical Coupling Plane (VCP).

Austin.Zhong

Reviewer: _____

9. RF FIELD STRENGTH SUSCEPTIBILITY TEST

9.1. Block Diagram of Test Setup

9.1.1. Block diagram of Test Setup

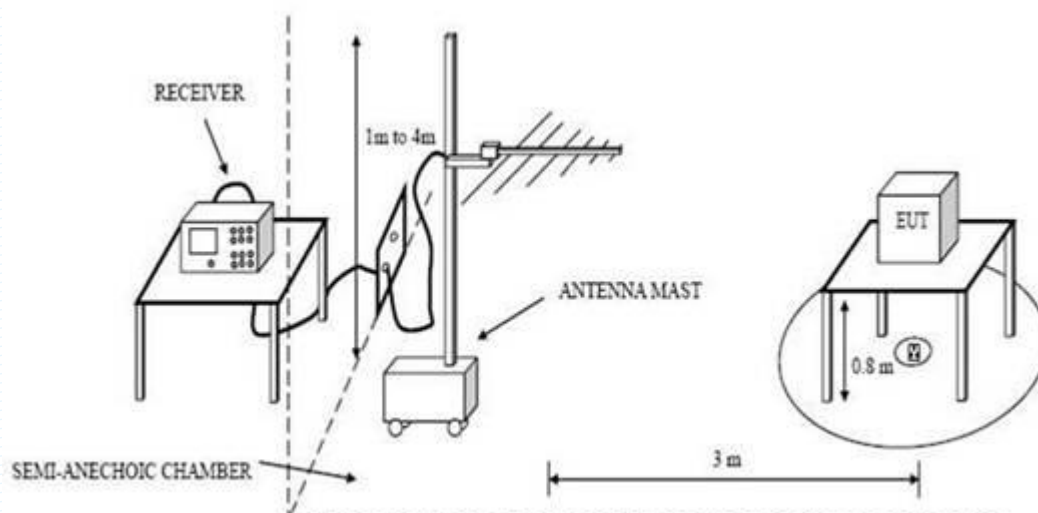

9.2. Test Standard

EN IEC 61000-6-1:2019 (EN 61000-4-3:2006+A2:2010)
Severity Level 2 at 3V/m

9.3. Severity level and Performance criterion

9.3.1. Severity level

Level	Field Strength V/m
1.	1
2.	3
3.	10
X.	Special

Performance criterion : A

9.4. EUT Configuration on Test

The configuration of EUT is listed in Section 4.4.

9.5. Operating Condition of EUT

Setup the EUT as shown in Section 9.1. The operating condition of EUT is listed in section 4.5.

9.6. Test Procedure

The EUT and its simulators are placed on a turn table which is 0.8 meter above the ground. The EUT is set 3 meters away from the transmitting antenna which is mounted on an antenna tower. Both horizontal and vertical polarization of the antenna are set on test. Each of the four sides of EUT must be faced this transmitting antenna and measured individually. In order to judge the EUT performance, a CCD camera is used to monitor the EUT. All the scanning conditions are as follows:

Condition of Test	Remarks
1. Fielded Strength	3 V/m (Severity Level 2)
2. Radiated Signal	Modulated
3. Scanning Frequency	80 - 1000 MHz
4. Sweeping time of radiated	0.0015 decade/s
5. Dwell Time	1 Sec.

9.7. Test Results

PASS

Please refer to the following page.

RF Field Strength Susceptibility Test Results

Beide (Shenzhen) Product Service Limited

Date: Mar.05, 2020

Applicant	: Shandong Xiaoya Group Household Appliances Co., Ltd.	Test Date	: Mar.05, 2020
EUT	: Ozone Air Sterillizer	Temperature	: 24°C
M/N	: XY-850S	Humidity	: 49%
Power Supply	: AC 230V	Test Mode	: ON
Test Engineer	: Jack	Frequency Range	: 80-1000MHz
Modulation:	<input checked="" type="checkbox"/> AM	<input type="checkbox"/> Pulse	<input type="checkbox"/> none
1 kHz 80%			
Criterion	: A		
		Frequency Range: 80-1000MHz	
Steps	1%	1%	
	Horizontal	Vertical	
Front	Pass	Pass	
Right	Pass	Pass	
Rear	Pass	Pass	
Left	Pass	Pass	

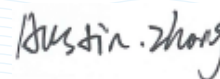

Reviewer : _____

10. ELECTRICAL FAST TRANSIENT/BURST TEST

10.1. Block Diagram of Test Setup

10.1.1. Block diagram of Test Setup

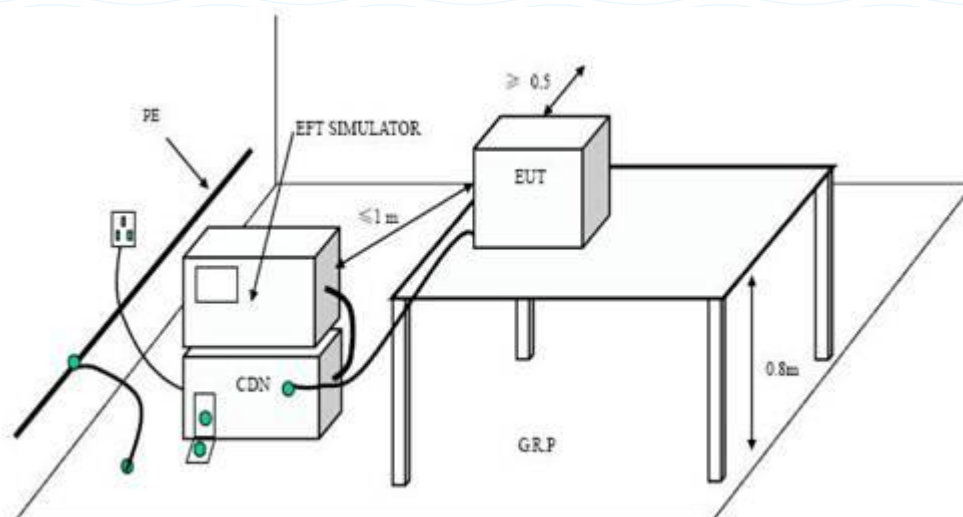

10.2. Test Standard

EN IEC 61000-6-1:2019 (EN 61000-4-4:2012)
Severity Level 2 at 1kV

10.3. Severity level and Performance criterion

10.3.1. Severity level

Level	Open Circuit Output Test Voltage $\pm 10\%$	
	On Power Supply Lines	On I/O (Input/Output) Signal data and control lines
1.	0.5 kV	0.25 kV
2.	1 kV	0.5 kV
3.	2 kV	1 kV
4.	4 kV	2 kV
X	Special	Special

Performance criterion : **B**

10.4. EUT Configuration on Test

The configuration of EUT is listed in Section 4.4.

10.5. Operating Condition of EUT

Setup the EUT as shown in Section 10.1. The operating condition of EUT is listed in section 4.5.

10.6. Test Procedure

The EUT is put on the table which is 0.8 meter high above the ground reference plane which is a min 1m*1m metallic sheet with 0.65mm minimum thickness. This reference ground plane shall project beyond the EUT by at least 0.8m on all sides and the minimum distance between the EUT and all other conductive structure, except the ground plane beneath the EUT, shall be more than 0.5m.

10.6.1. For input and output AC power ports:

The EUT is connected to the power mains by using a coupling device which couples the EFT interference signal to AC power lines. Both polarities of the test voltage should be applied during compliance test and the duration of the test is 2 mins.

10.6.2. For signal lines and control lines ports:

It's unnecessary to test.

10.6.3. For DC output line ports:

It's unnecessary to test.

10.7. Test Results

PASS

Please refer to the following page.

Electrical Fast Transient/Burst Test Results

Beide (Shenzhen) Product Service Limited

Date: Mar.05, 2020

Applicant	: Shandong Xiaoya Group	Test Date	: Mar.05, 2020						
	Household Appliances Co., Ltd.								
EUT	: Ozone Air Sterillizer	Temperature	: 24°C						
M/N	: XY-850S	Humidity	: 49%						
Power Supply	: AC 230V	Test Mode	: ON						
Test Engineer	: Jack								
Inject Place : AC Mains									
Inject Line	Voltage kV	Inject Time(s)	Inject Method	Results	Inject Line	Voltage kV	Inject Time(s)	Inject Method	Results
L	±1	120	Direct	PASS					
N	±1	120	Direct	PASS					
L、N	±1	120	Direct	PASS					

Reviewer: _____

Austin Zhong

11. SURGE TEST

11.1. Block Diagram of Test Setup

11.1.1. Block diagram of Test Setup

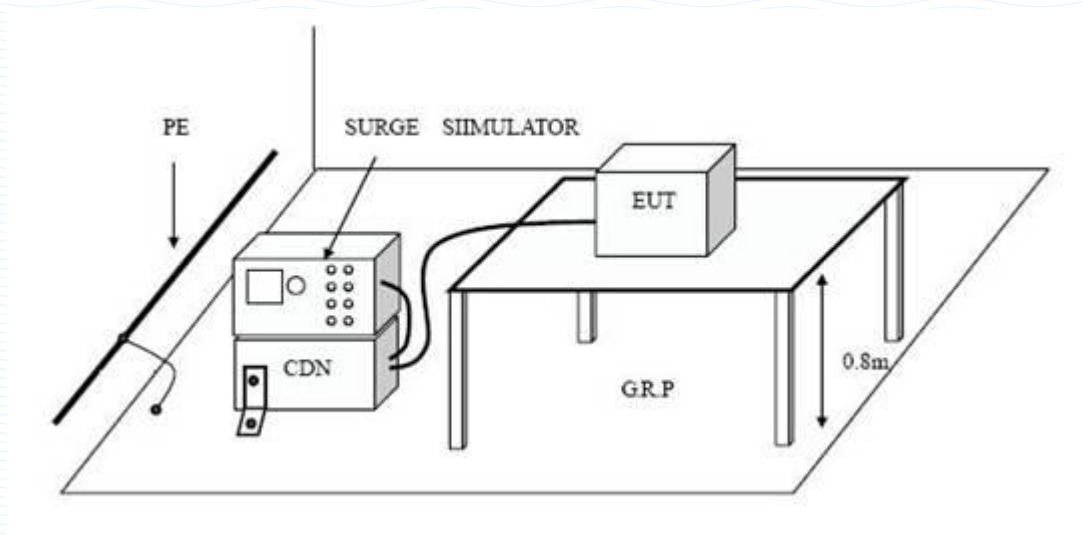

11.2. Test Standard

EN IEC 61000-6-1:2019 (EN 61000-4-5:2014)

Severity Level 2 at 1kV for line-line, Severity Level 3 at 2 kV for line-earth

11.3. Severity level and Performance criterion

11.3.1. Severity level

Severity Level	Open-Circuit Test Voltage kV
1	5
2	0
3	0
4	4.0
*	Special

Performance criterion: **B**

11.4. EUT Configuration on Test

The configuration of EUT is listed in Section 4.4.

11.5. Operating Condition of EUT

Setup the EUT as shown in Section 11.1. The operating condition of EUT is listed in section 4.5.

11.6. Test Procedure

- 1) Set up the EUT and test generator as shown on section 11.1.1.
- 2) For line to line coupling mode, provide a 1kV 1.2/50us voltage surge (at open-circuit condition) and 8/20us current surge to EUT selected points.
- 3) At least 5 positive and 5 negative (polarity) tests with a maximum 1/min repetition rate are conducted during test.
- 4) Different phase angles are done individually.
- 5) Repeat procedure 2) to 4) except the open-circuit test voltage change from 1kV to 2kV for line to earth coupling mode test.
- 6) Record the EUT operating situation during compliance test and decide the EUT immunity criterion for above each test.

11.7. Test Results

PASS

Please refer to the following page.



Beide

Surge Immunity Test Results

Beide (Shenzhen) Product Service Limited.

Date: Mar.05, 2020

Applicant : <u>Shandong Xiaoya Group Household Appliances Co., Ltd.</u>				Test Date : <u>Mar.05, 2020</u>	
EUT : <u>Ozone Air Sterillizer</u>				Temperature : <u>24°C</u>	
M/N : <u>XY-850S</u>				Humidity : <u>49%</u>	
Power Supply : <u>AC 230V</u>				Test Mode : <u>ON</u>	
Location	Polarity	Phase Angle	No of Pulse	Pulse Voltage (kV) EN 61000-4-5	Result
L-N	+	0	5	1	Pass
	+	90	5	1	Pass
	+	180	5	1	Pass
	+	270	5	1	Pass
	-	0	5	1	Pass
	-	90	5	1	Pass
	-	180	5	1	Pass
	-	270	5	1	Pass
Remark:					

Reviewer: _____

Austin.Zhong

12. INJECTED CURRENTS SUSCEPTIBILITY TEST

12.1. Block Diagram of Test Setup

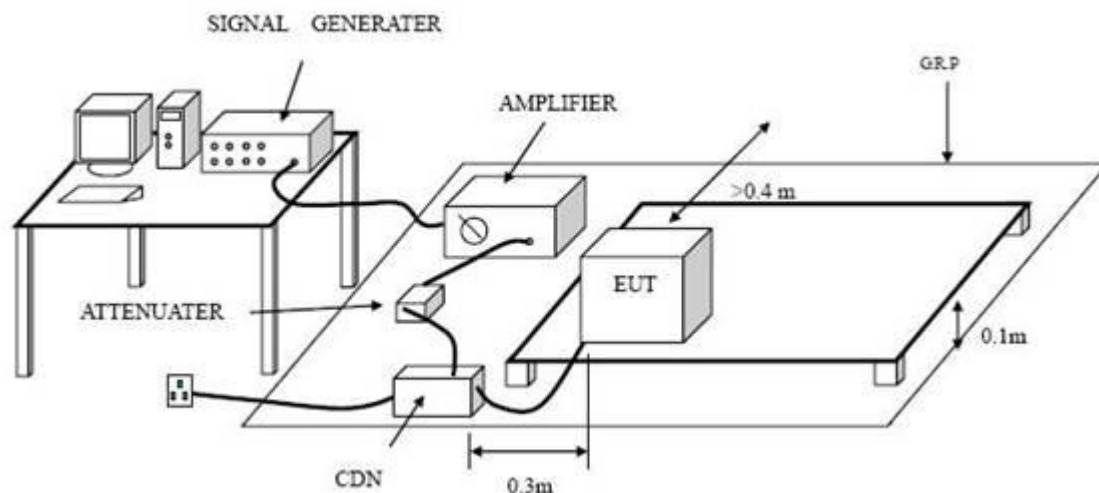

12.2. Test Standard

EN IEC 61000-6-1:2019 (EN 61000-4-6:2014)
Severity Level 3 at 10V (rms), 0.15MHz ~ 80MHz

12.3. Severity Levels and Performance Criterion

12.3.1 Severity level

Level	Field Strength V/m
1.	1
2.	3
3.	10
X	Special

Performance criterion: A

12.4. EUT Configuration on Test

The configuration of EUT is listed in Section 4.4.

12.5. Operating Condition of EUT

12.5.1 Setup the EUT as shown in Section 12.1.

12.5.2 Turn on the power of all equipments.

12.6. Test Procedure

- 1) Set up the EUT, CDN and test generators as shown on Section 12.1.2.
- 2) Let the EUT work in test mode and test it.
- 3) The EUT are placed on an insulating support 0.8m high above a ground reference plane. CDN(coupling and decoupling device) is placed on the ground plane about 0.3m from EUT. Cables between CDN and EUT are as short as possible, and their height above the ground reference plane shall be between 30 and 50 mm (where possible).
- 4) The disturbance signal described below is injected to EUT through CDN.
- 5) The EUT operates within its operational mode(s) under intended climatic conditions after power on.
- 6) The frequency range is swept from 150 kHz to 80MHz using 3V signal level, and with the disturbance signal 80% amplitude modulated with a 1 kHz sine wave.
- 7) The rate of sweep shall not exceed 1.5×10^{-3} decades/s. Where the frequency is swept incrementally, the step size shall not exceed 1% of the start and thereafter 1% of the preceding frequency value.
- 8) Recording the EUT operating situation during compliance testing and decide the EUT immunity criterion.

12.7. Test Results

PASS

Please refer to the following page.

Injected Currents Susceptibility Test Results

Beide (Shenzhen) Product Service Limited

Date: Mar.05, 2020

Applicant : Shandong Xiaoya Group Household Appliances Co., Ltd. <hr/> EUT : Ozone Air Sterillizer <hr/> M/N : XY-850S Power Supply : AC 230V Test Engineer : Jack			Test Date : <u>Mar.05, 2020</u> Temperature : <u>24°C</u> Humidity : <u>49%</u> Test Mode : <u>ON</u>	
Frequency Range (MHz)	Injected Position	Strength	Criterion	Result
0.15 ~ 80	AC Mains	10V(rms), Unmodulated	A	PASS
Remark : 1. Modulation Signal:1kHz 80% AM			Note:	

Reviewer: Austin.Zhong

13. VOLTAGE DIPS AND INTERRUPTIONS TEST

13.1. Block Diagram of Test Setup

13.1.1. Block diagram of Test Setup

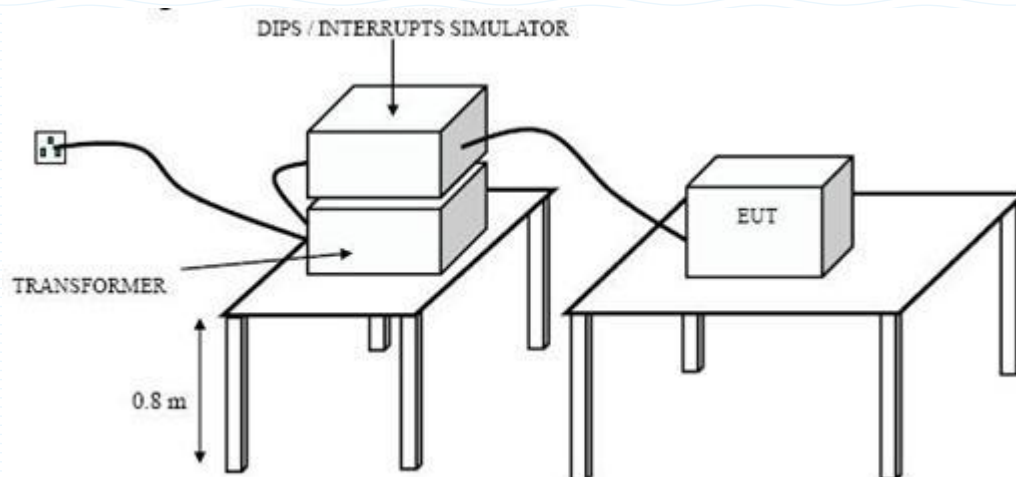

13.2. Test Standard

EN IEC 61000-6-1:2019 (EN 61000-4-11: 2004)

13.3. Severity level and Performance criterion

13.3.1. Severity level

Test Level $\% U_T$	Voltage dip and short interruptions $\% U_T$	Duration (in period)
0	100	250
0	100	0.5
70	30	25

Performance criterion : B

13.4. EUT Configuration

The configuration of EUT is listed in section 4.4

13.5. Operating Condition of EUT

- 13.5.1. Setup the EUT as shown on Section 13.1.1.
- 13.5.2. Turn on the power of all equipments.
- 13.5.3. Let the EUT work in test mode (ON) and measure it and test it.

13.6. Test Procedure

- 1) Set up the EUT and test generator as shown on section 13.1.1.
- 2) The interruption is introduced at selected phase angles with specified duration. There is a 3mins minimum interval between each test event.
- 3) After each test a full functional check is performed before the next test.
- 4) Repeat procedures 2 & 3 for voltage dips, only the test level and duration is changed.
Record any degradation of performance.

13.7. Test Results

PASS

Please refer to the following page.

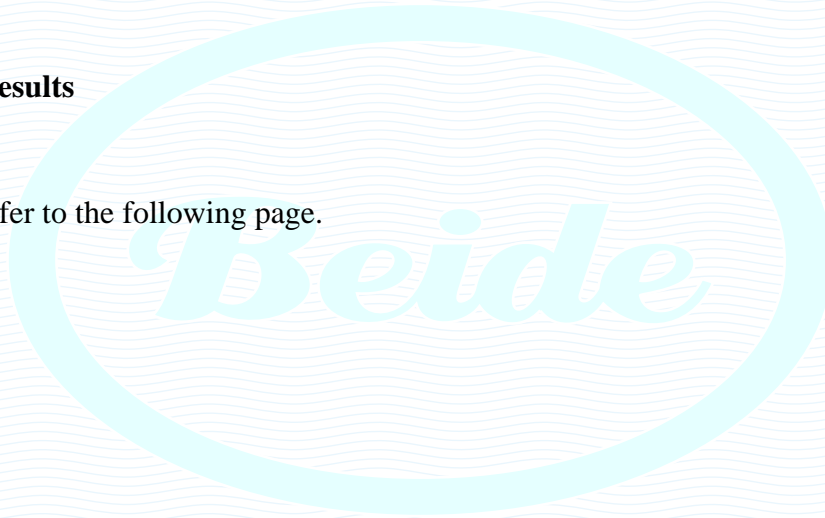

Voltage Dips And Interruptions Test Results

Beide (Shenzhen) Product Service Limited

Date: Mar.05, 2020

Applicant : Shandong Xiaoya Group Household Appliances Co., Ltd.				Test Date : <u>Mar.05, 2020</u>	
EUT : <u>Ozone Air Sterillizer</u>				Temperature : <u>24°C</u>	
M/N : <u>XY-850S</u>				Humidity : <u>49%</u>	
Power Supply : <u>AC 230V</u>					
<input checked="" type="checkbox"/> Single Test Voltage			<input type="checkbox"/> Dual Test Voltage		
Test Mode: ON					
Test Level % U _T	Voltage Dips & Short Interruptions % U _T	Duration (in period)	Phase Angle	Criterion	Result
0	100	250P	0-360	B	Pass
40	60	25P	0-360	B	Pass
0	100	0.5P	0-360	B	Pass
Remark: U _T is the rated voltage for the equipment.					

Reviewer: Austin Zhang



APPENDIX I
(Test Data)

Job No.:		Polarization:	Horizontal
Standard:	EN 61000-6-3 ClassB	Power Source:	AC 230V
Test item:	Radiation Test	Date:	2020/03/09
Temp.(°C)/Hum.(%RH):	24°C/47%RH	Time:	
EUT:	Ozone Air Sterilizer	Test By:	
Model:	XY-850S	Distance:	3m
Note:			

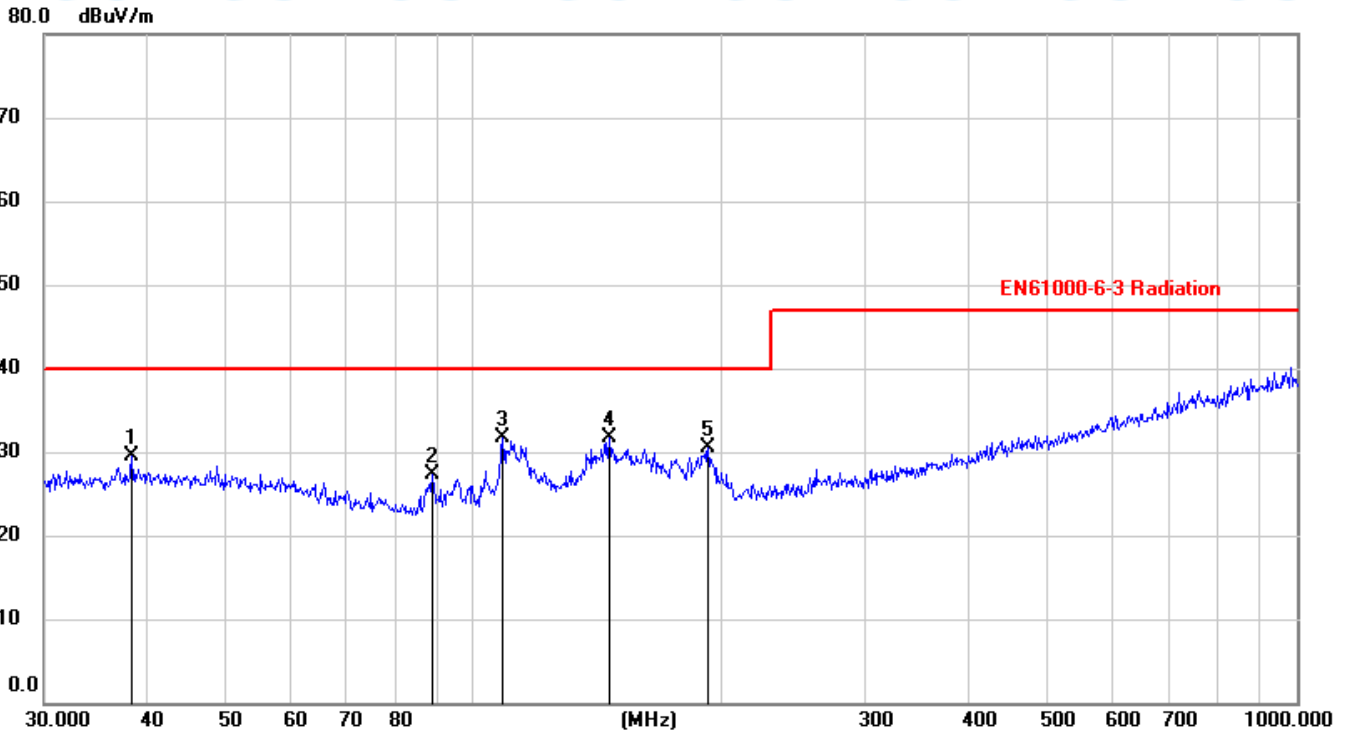

No.	Mk.	Freq.	Reading Level	Correct Factor	Measurement	Limit	Margin	Antenna Height	Table Degree	
		MHz	dBuV	dB	dBuV/m	dBuV/m	dB	cm	degree	Comment
1		38.4304	15.15	14.28	29.43	40.00	-10.57	peak		
2		89.0419	17.25	10.07	27.32	40.00	-12.68	peak		
3	*	108.4567	20.12	11.68	31.80	40.00	-8.20	peak		
4		146.1811	16.90	14.72	31.62	40.00	-8.38	peak		
5		192.5029	19.17	11.29	30.46	40.00	-9.54	peak		

Job No.:		Polarization:	Vertical
Standard:	EN 61000-6-3 ClassB	Power Source:	AC 230V
Test item:	Radiation Test	Date:	2020/03/09
Temp.(°C)/Hum.(%RH):	24°C/47%RH	Time:	
EUT:	Ozone Air Sterillizer	Test By:	
Model:	XY-850S	Distance:	3m
Note:			

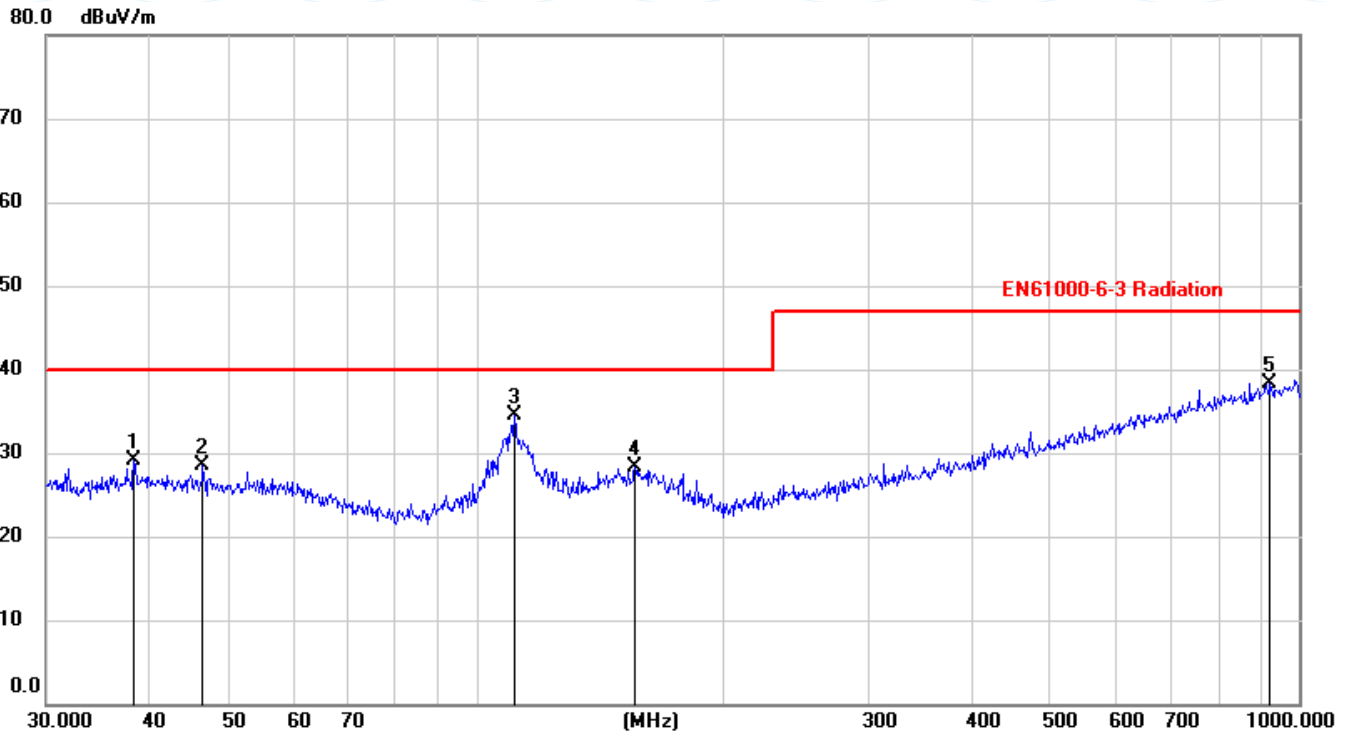

No.	Mk.	Freq. MHz	Reading Level dBuV	Correct Factor dB	Measure- ment dBuV/m	Limit dBuV/m	Margin dB	Antenna Height cm	Table Degree degree	Comment
1		38.3967	14.78	14.26	29.04	40.00	-10.96			peak
2		46.6664	14.41	14.06	28.47	40.00	-11.53			peak
3	*	111.6401	22.55	12.02	34.57	40.00	-5.43			peak
4		156.0468	13.33	14.99	28.32	40.00	-11.68			peak
5		922.5157	13.79	24.57	38.36	47.00	-8.64			peak

Job No.:		Polarization:	Line
Standard:	EN 61000-6-3 ClassB	Power Source:	AC 230V
Test item:	Conduct Test	Date:	2020/03/09
Temp.(°C)/Hum.(%RH):	24°C/47%RH	Time:	
EUT:	Ozone Air Sterillizer	Test By:	
Model:	XY-850S	Distance:	-
Note:			

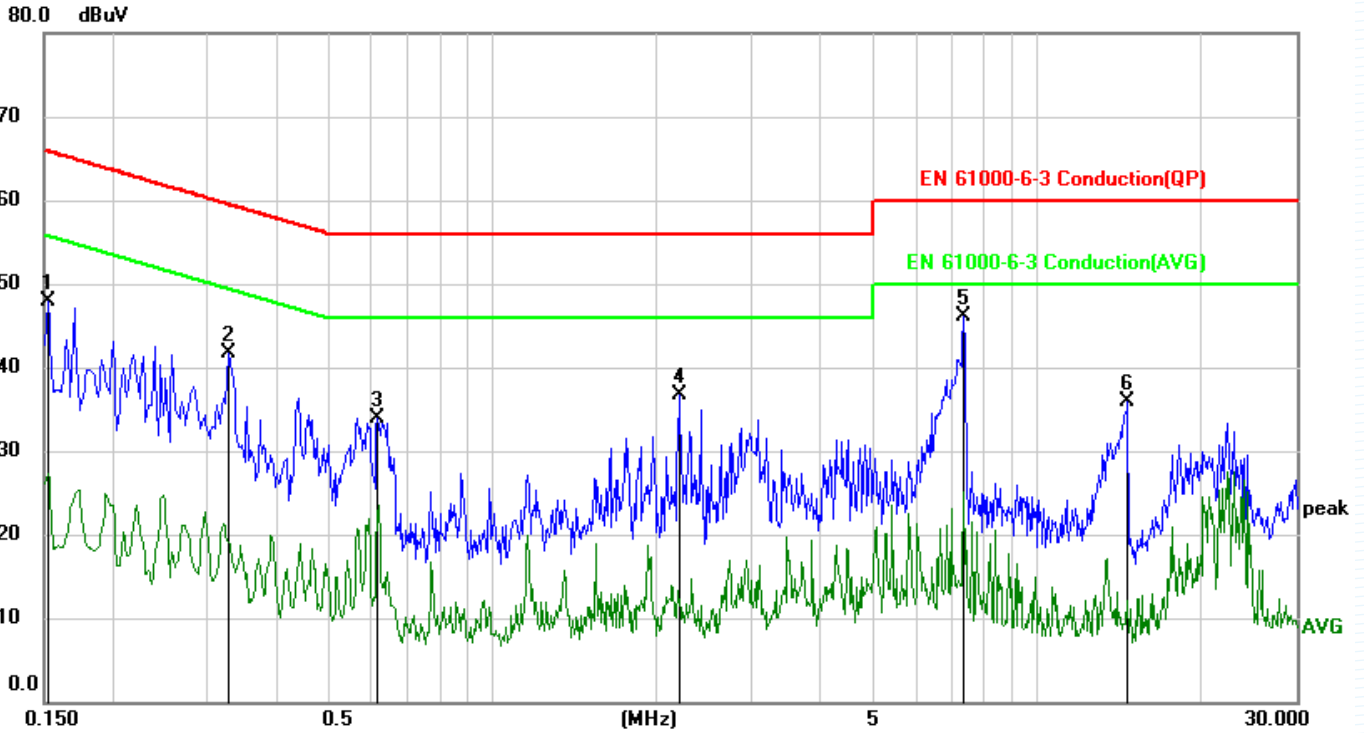

No.	Mk.	Freq. MHz	Reading Level dBuV	Correct Factor dB	Measure- ment dBuV	Limit dBuV	Margin dB	Detector	Comment
1		0.1530	38.03	9.94	47.97	65.84	-17.87	peak	
2		0.3270	31.79	9.94	41.73	59.53	-17.80	peak	
3		0.6150	24.07	9.92	33.99	56.00	-22.01	peak	
4		2.2020	26.76	9.89	36.65	56.00	-19.35	peak	
5	*	7.3560	35.90	10.13	46.03	60.00	-13.97	peak	
6		14.7330	25.66	10.32	35.98	60.00	-24.02	peak	

Job No.:		Polarization:	Neutral
Standard:	EN 61000-6-3 ClassB	Power Source:	AC 230V
Test item:	Conduct Test	Date:	2020/03/09
Temp.(°C)/Hum.(%RH):	24°C/47%RH	Time:	
EUT:	Ozone Air Sterilizer	Test By:	
Model:	XY-850S	Distance:	-
Note:			

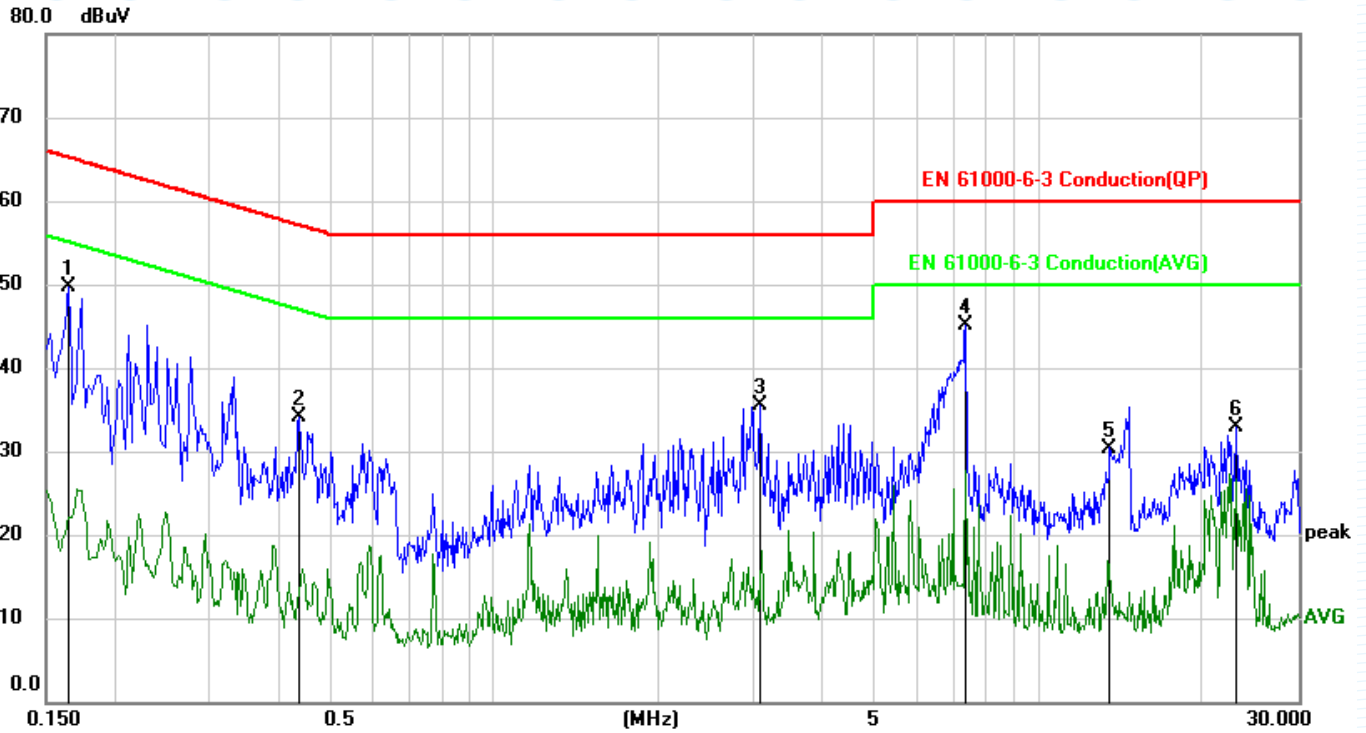

No.	Mk.	Freq. MHz	Reading Level dBuV	Correct Factor dB	Measure- ment dBuV	Limit dBuV	Margin dB	Detector	Comment
1		0.1650	39.76	9.93	49.69	65.21	-15.52	peak	
2		0.4380	24.06	9.95	34.01	57.10	-23.09	peak	
3		3.0750	25.63	9.96	35.59	56.00	-20.41	peak	
4	*	7.3530	35.01	10.13	45.14	60.00	-14.86	peak	
5		13.4820	20.11	10.29	30.40	60.00	-29.60	peak	
6		23.1299	22.51	10.45	32.96	60.00	-27.04	peak	

APPENDIX II
(EUT Photos)

Beide

Figure 1
APPEARANCE OF EUT



Figure 2
APPEARANCE OF EUT



Figure 3
APPEARANCE OF EUT

